

NOTES:

- OFFSET 'X' TO NOSE OF ISLAND TO BE FROM FACE OF ULTIMATE DESIGN KERB AND CHANNEL ALIGNMENT. OFFSET 'X' = 0.2 M FOR EACH 10 KM/H OF DESIGN APPROACH SPEED. MINIMUM 0.5 M, DESIRABLE 1.2 M. (TO BE ADOPTED UNLESS OTHERWISE SPECIFIED)
- LINE MARKING MUST ACCOMPANY ISLAND CONSTRUCTION
- LONGITUDINAL LENGTH OF 'W' AND 'Y' MAY VARY DEPENDANT UPON
 1. OFFSET 'X' TO NOSE OF ISLAND
 2. TAIL OF ISLAND TO TERMINATE
 3. 1.4 M PED. CROSSING TO ALIGN WITH EXISTING PRAM CROSSINGS.
- DIMENSIONS AND OFFSETS (UNLESS OTHERWISE SPECIFIED) SHALL ACCORD WITH THE FOLLOWING TABLE

	'S'	'G'	'T'
LOCAL ROADS	<7.6	N/A	N/A
	7.6	3.8	3.8
	8.8	4.4	4.4
COLLECTOR ROADS	11.3	5.0	6.3
	>11.3	VARIES	6.3
	13.0	6.6	6.4

- INSTALL SOCKET WITH 225 MM LEGS PLACED AS SHOWN. SIGN R2-3A (L) TO BE INSTALLED AT A LATER DATE IF REQUIRED.

- LINES A-B AND A-C TO BE FORMED AS STRAIGHT LINES.
- PAINT ISLAND SHALL BE FORMED IN 100 WIDE LONGLIFE WHITE LINEMARKING PAINT. CHEVRON BARS SHALL BE 300 WIDE WITH 600 SPACING.

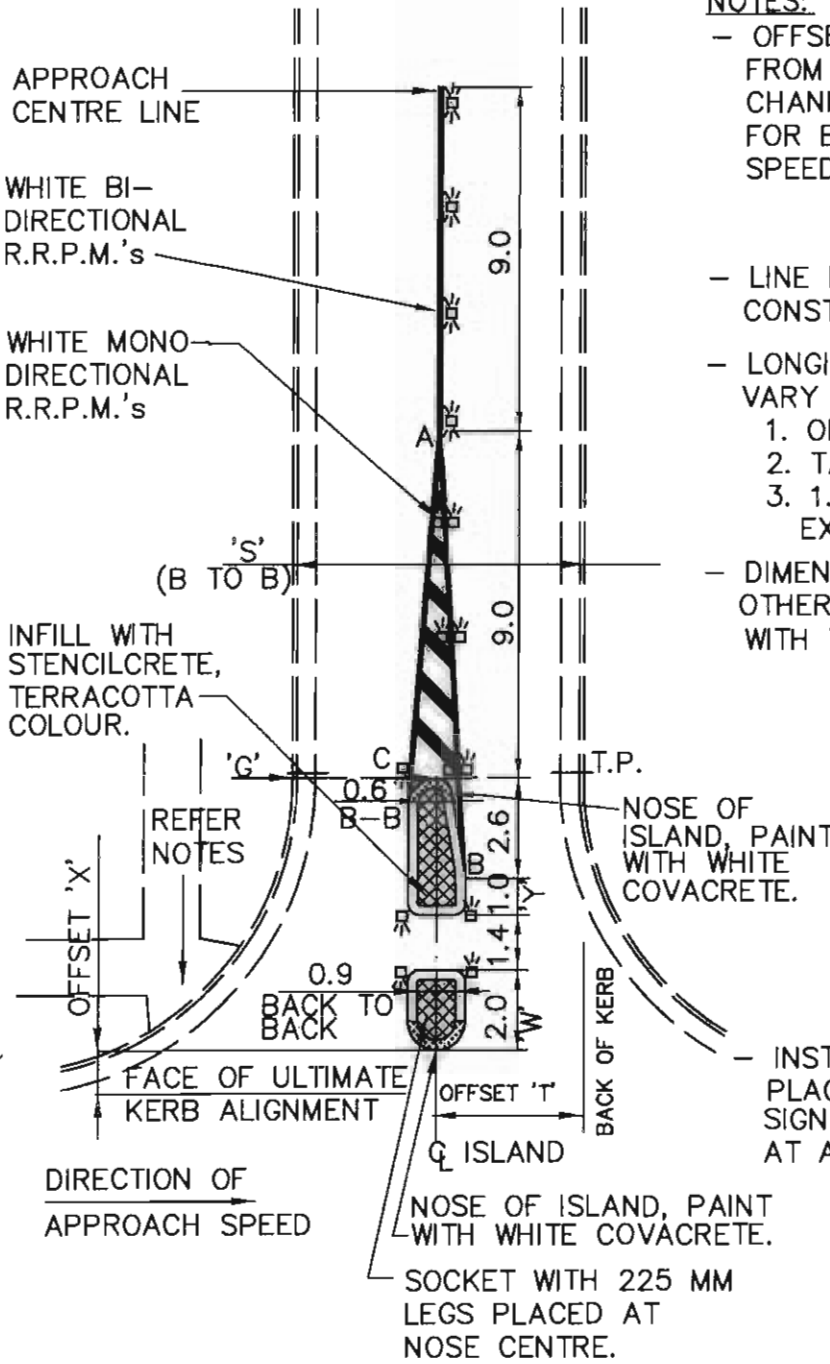

LAYOUT DETAIL

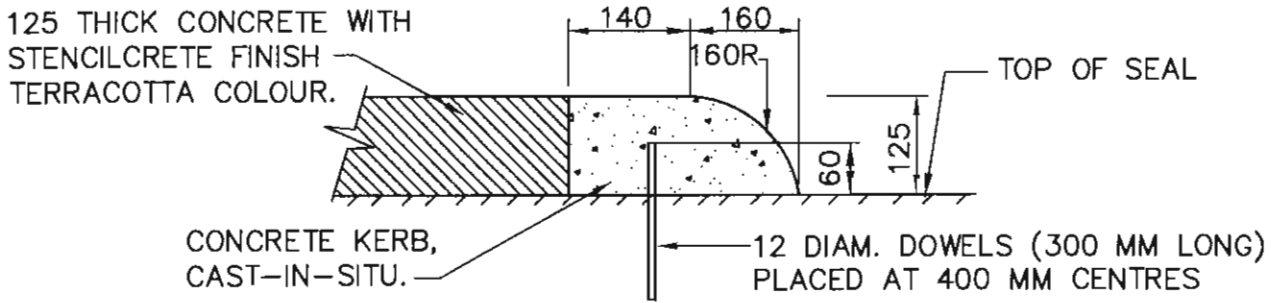

KERB DETAIL

REFER TO S310.1/S310.2 FOR TACTILE TILE REQUIREMENTS.

CHECKED
Jan Stacey

APPROVED
Jan Stacey

SCALE
N.T.S.

KNOX CITY COUNCIL

**SPLITTER ISLAND
SPIKED TO PAVEMENT**

DATE
1-8-2001

REVISION

CAD FILE NAME
S 350.1

NOTES:

- OFFSET 'X' TO NOSE OF ISLAND TO BE FROM FACE OF ULTIMATE DESIGN KERB AND CHANNEL ALIGNMENT. OFFSET 'X' = 0.2 M FOR EACH 10 KM/H OF DESIGN APPROACH SPEED. MINIMUM 0.5 M, DESIRABLE 1.2 M. (TO BE ADOPTED UNLESS OTHERWISE SPECIFIED)
- LONGITUDINAL LENGTH OF 'W' AND 'Y' MAY VARY DEPENDANT UPON
 1. OFFSET 'X' TO NOSE OF ISLAND
 2. TAIL OF ISLAND TO TERMINATE
 3. 1.4 M PED. CROSSING TO ALIGN WITH EXISTING PRAM CROSSINGS.
- DIMENSIONS AND OFFSETS (UNLESS OTHERWISE SPECIFIED) SHALL ACCORD WITH THE FOLLOWING TABLE

	'S'	'G'	'T'
LOCAL ROADS	<7.6	N/A	N/A
	7.6	3.8	3.8
	8.8	4.4	4.4
COLLECTOR ROADS	11.3	5.0	6.3
	>11.3	VARIES	6.3
	13.0	6.6	6.4

- ISLAND SHALL BE FORMED IN 100 WIDE WHITE LONGLIFE LINEMARKING PAINT. CHEVRON BARS SHALL BE 300 WIDE WITH 600 SPACING.

- LINES A-B AND A-C TO BE FORMED AS STRAIGHT LINES.

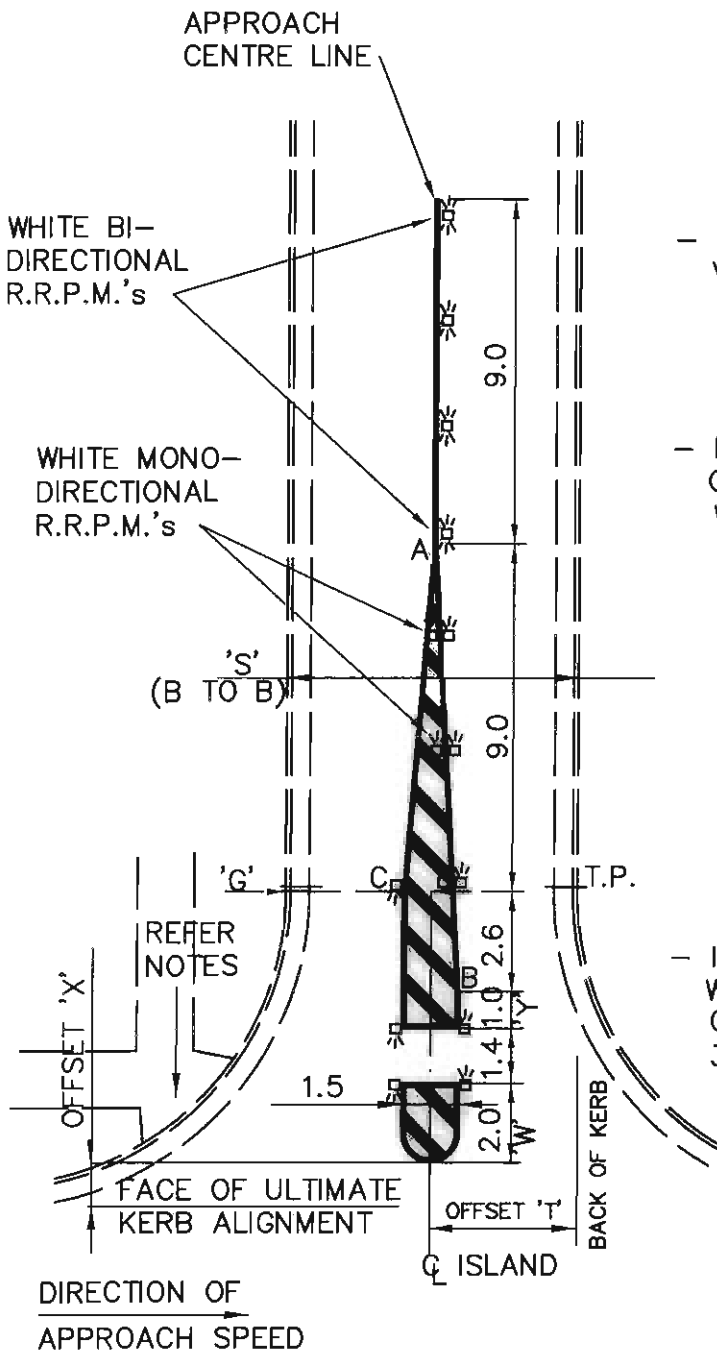

LAYOUT DETAIL

REFER TO S310.1/S310.2 FOR TACTILE TILE REQUIREMENTS.

CHECKED <i>Jan Stacey</i>	<h1 style="margin: 0;">KNOX CITY COUNCIL</h1>	DATE 1-8-2001
APPROVED <i>Jan Stacey</i>	<h2 style="margin: 0;">SPLITTER ISLAND PAINTED</h2>	REVISION
SCALE N.T.S.		CAD FILE NAME S 350.2